

Terminals : male FASTON (.250 series / 6,3x0,8 mm)

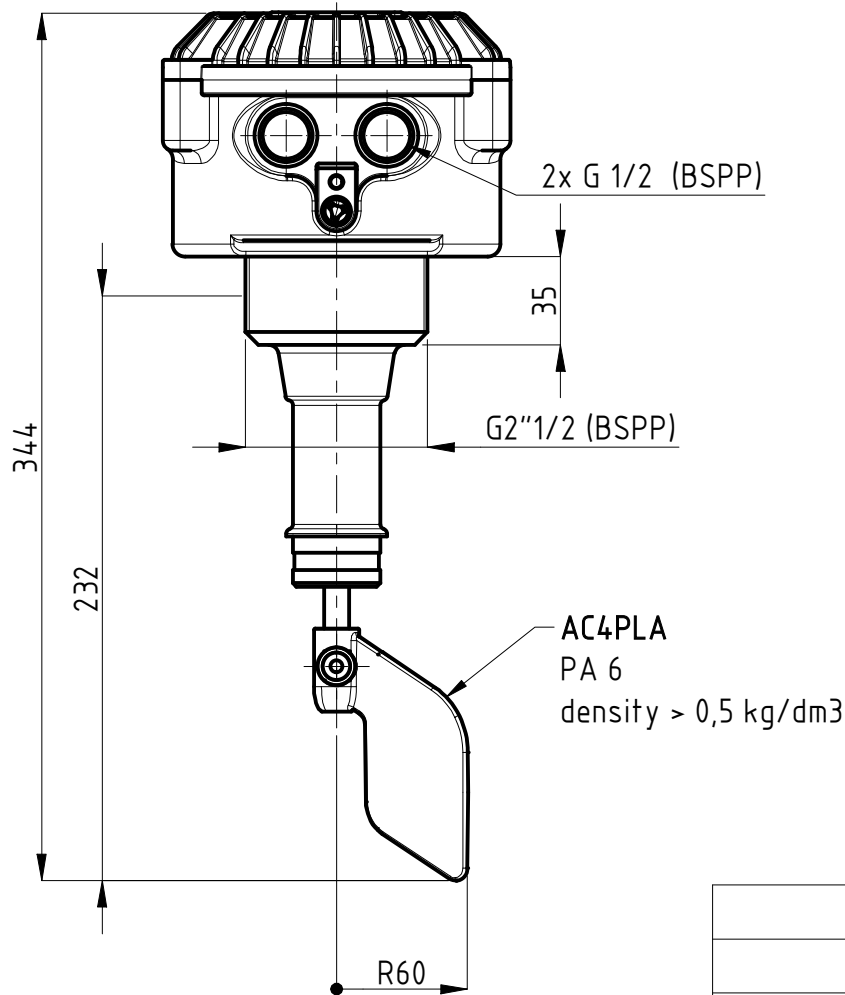

PFG05

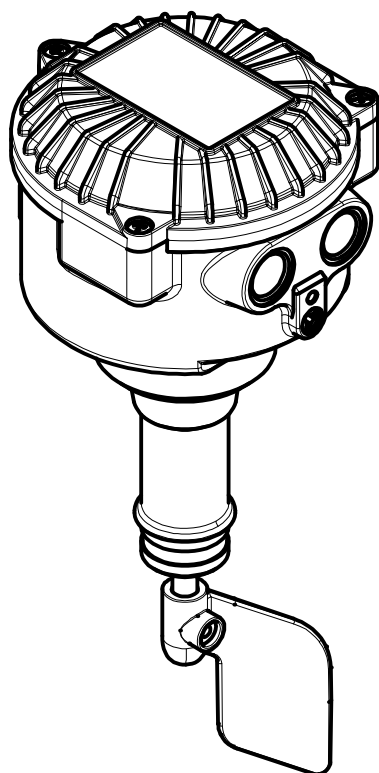

Model	PFG05
Weight	1,8 [kg]
Power supply	- Bivoltage 115/230[V] (50...60Hz) - 4[W] - Bivoltage 24/48[V] (50...60Hz) - 4[W] - DC 24[V] ±15% - 4[W]
Signal	SPDT / max. 10[A]-250VAC
IP grade	IP65
Housing	Aluminium (powder coated)
Connection	G2'' 1/2 - Aluminium
Ambient temperature	-20 < Ta < +70 [°C] -40 < Ta < +70 [°C] <i>LOW TEMPERATURE versions only (PFG.../B)</i>
Process temperature	-20 < Tp < +70 [°C] -40 < Tp < +70 [°C] <i>LOW TEMPERATURE versions only (PFG.../B)</i>
Pressure range	+0,8 ... +1,1 bar [abs] +0,8 ... +5 bar [abs] <i>(non-ATEX versions)</i>
Directives	2011/65/EU (RoHS) 2014/30/EU (EMC) 2014/34/EU (ATEX) 2014/35/EU (LVD)
ATEX Marking	Ex II 1/2 D Ex ta/tb IIIC T85°C IP65 Da/Db Ex II 3 D Ex tc IIIB T85°C Dc (Lamp version)
IECEX Marking	Ex ta/tb IIIC T85°C Da/Db

<p>® CAMLogic Via dell'Industria 12 42025 Cavriago (RE) - ITALY www.camlogic.it</p>	<p><b>CAMLogic</b>®</p>	DRAWING N.	SHEET:
		0602_0001_00	1 OF 5
GENERAL TOL.: ISO 2768-mH	UNLESS OTHERWISE SPECIFIED DIMENSION ARE IN [mm]	DRAWING FROM CAD SYSTEM - REFER TO 3D MODEL FOR MISSING DIMENSION - NO MANUAL MODIFICATION ALLOWED	SCALE: 1:3
			REV: 1 DATE 21.09.2021

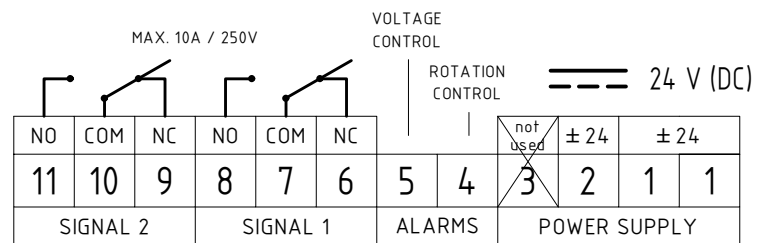
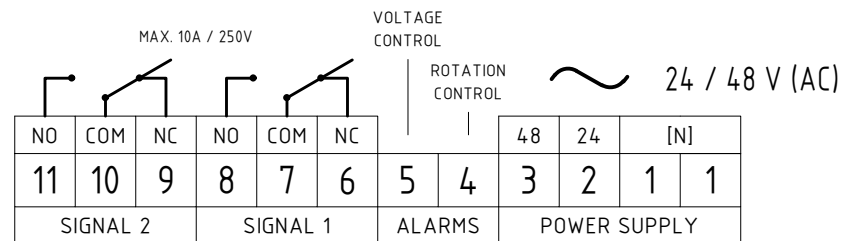
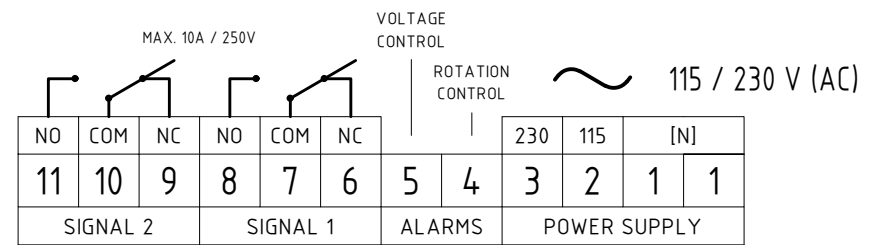
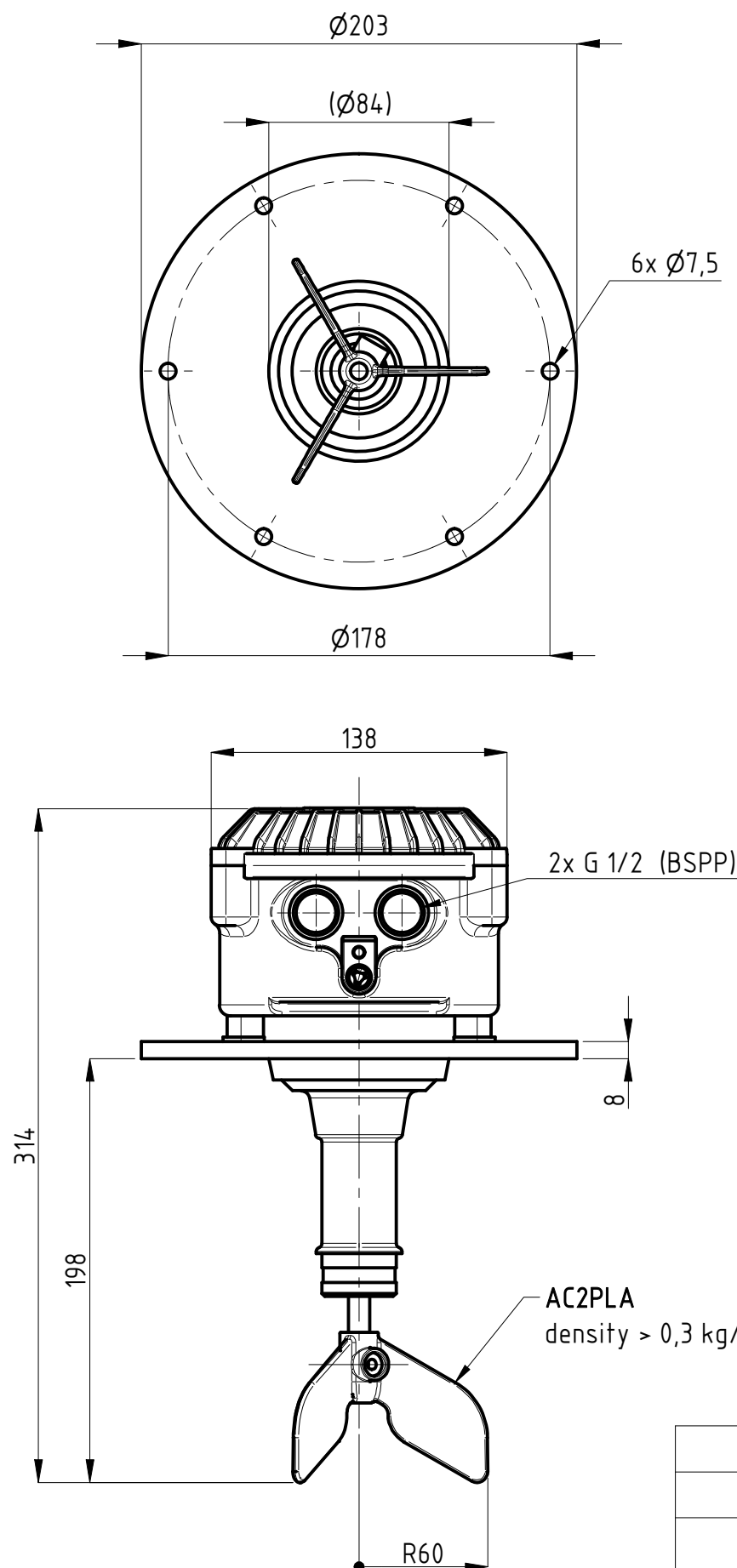

Terminals : male FASTON (.250 series / 6,3x0,8 mm)

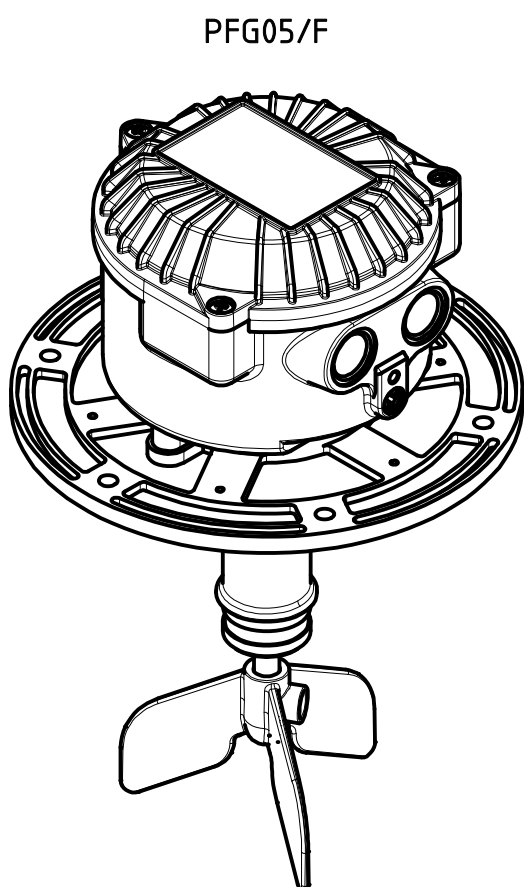

Model	PFG05/F
Weight	2,3 [kg]
Power supply	Bivoltage 115/230[V] (50...60Hz) - 4[W] Bivoltage 24/48[V] (50...60Hz) - 4[W] DC 24[V] ±15% - 4[W]
Signal	SPDT / max. 10[A]-250VAC
IP grade	IP65
Housing	Aluminium (powder coated)
Connection	Flange - Aluminium
Ambient temperature	-20 < Ta < +70 [°C] -40 < Ta < +70 [°C] <i>LOW TEMPERATURE versions only (PFG.../B)</i>
Process temperature	-20 < Tp < +70 [°C] -40 < Tp < +70 [°C] <i>LOW TEMPERATURE versions only (PFG.../B)</i>
Pressure range	+0,8 ... +1,1 bar [abs] +0,8 ... +5 bar [abs] <i>(non-ATEX versions)</i>
Directives	2011/65/EU (RoHS) 2014/30/EU (EMC) 2014/34/EU (ATEX) 2014/35/EU (LVD)
ATEX Marking	Ex II 1/2 D Ex ta/tb IIIC T85°C IP65 Da/Db Ex II 3 D Ex tc IIIB T85°C Dc (Lamp version)
IECEX Marking	Ex ta/tb IIIC T85°C Da/Db

<b>® CAMLogic</b> Via dell'Industria 12 42025 Cavriago (RE) - ITALY www.camlogic.it	<b>CAMLogic</b> ®	DRAWING N.	SHEET:
		0602_0001_00	2 OF 5
GENERAL TOL.: ISO 2768-mH	UNLESS OTHERWISE SPECIFIED DIMENSION ARE IN [mm]	DRAWING FROM CAD SYSTEM - REFER TO 3D MODEL FOR MISSING DIMENSION - NO MANUAL MODIFICATION ALLOWED	SCALE: 1:3
			REV: 1 DRAWN NR DATE 21.09.2021

**EXTENSIONS**

**L1 [mm]**

Extension w/o protection  
 PSP : galvanized steel  
 PSPX : stainless steel

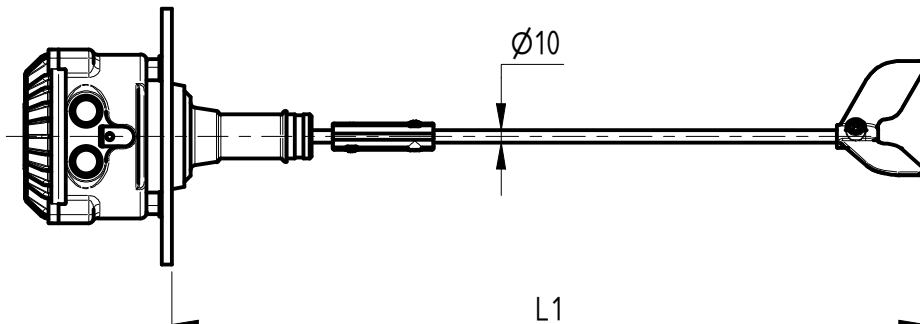

Extension with external protection  
 PCP : galvanized steel  
 PCPX : stainless steel

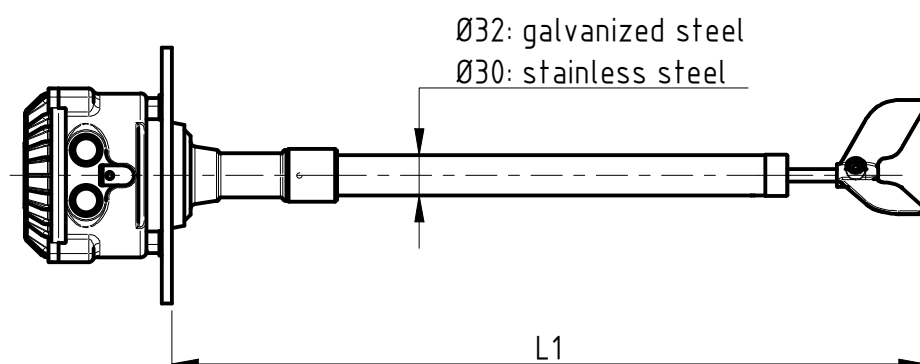

300
400
500
600
700
800
900
1000
1200
1500
1800
2000
2500
3000
other lengths available on request, up to 3m

**L1 [mm]**

600
700
800
900
1000
1200
1500
1800
2000
2500
3000
other lengths available on request, up to 3m

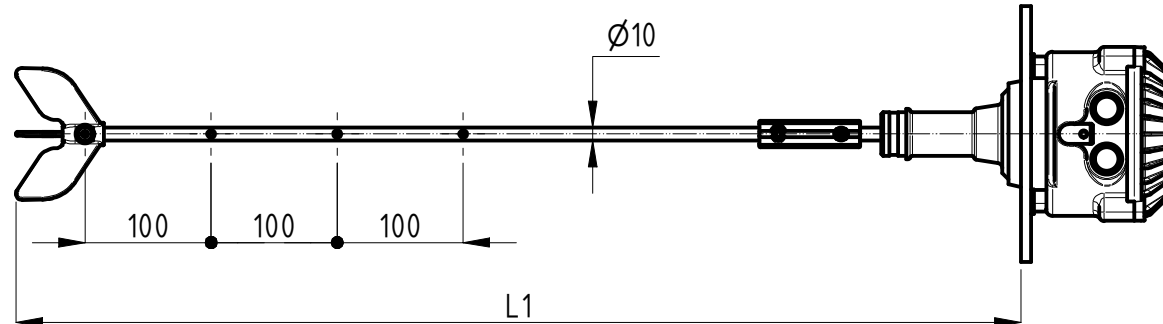

Adjustable extension w/o protection  
 PRS : galvanized steel  
 PRSX : stainless steel

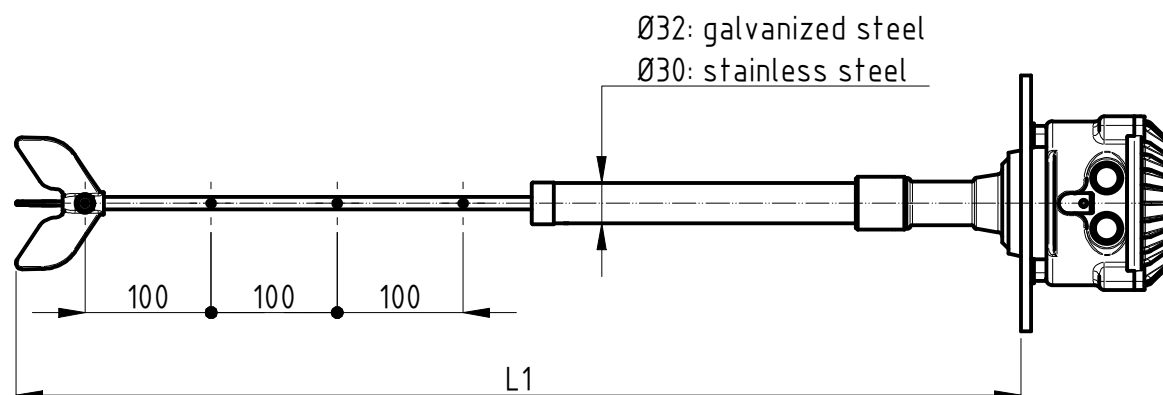

Extension with external protection  
 PRP : galvanized steel  
 PRPX : stainless steel

Flexible extension  
 PF : galvanized steel

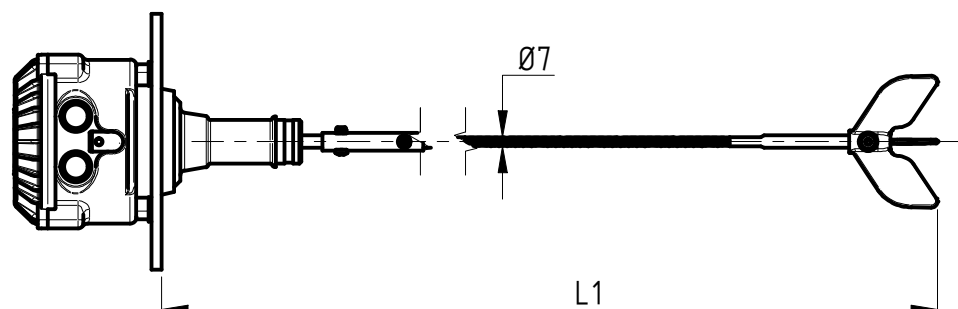

<b>L1 [mm]</b>
500
600
700
800
900
1000
1200
1500
2000
2500
3000
4000

<b>L1 [mm]</b>
5000
6000
7000
8000
9000
10000
11000
12000
other lengths available on request, up to 12m

NOTE : lenghts may slightly differ from the tables according to the type of connection, model and paddle chosen

**CAMLogic**  
 Via dell'Industria 12  
 42025 Cavriago (RE) - ITALY  
 www.camlogic.it

**CAMLogic**

DRAWING N. **0602\_0001\_00**

SHEET: **3 OF 5**

GENERAL TOL.: ISO 2768-mH

UNLESS OTHERWISE SPECIFIED DIMENSION ARE IN [mm]

DRAWING FROM CAD SYSTEM - REFER TO 3D MODEL FOR MISSING DIMENSION - NO MANUAL MODIFICATION ALLOWED

SCALE: **1:6**

DRAWN NR DATE 30.09.2021

SIZE UNI A3

PADDLES

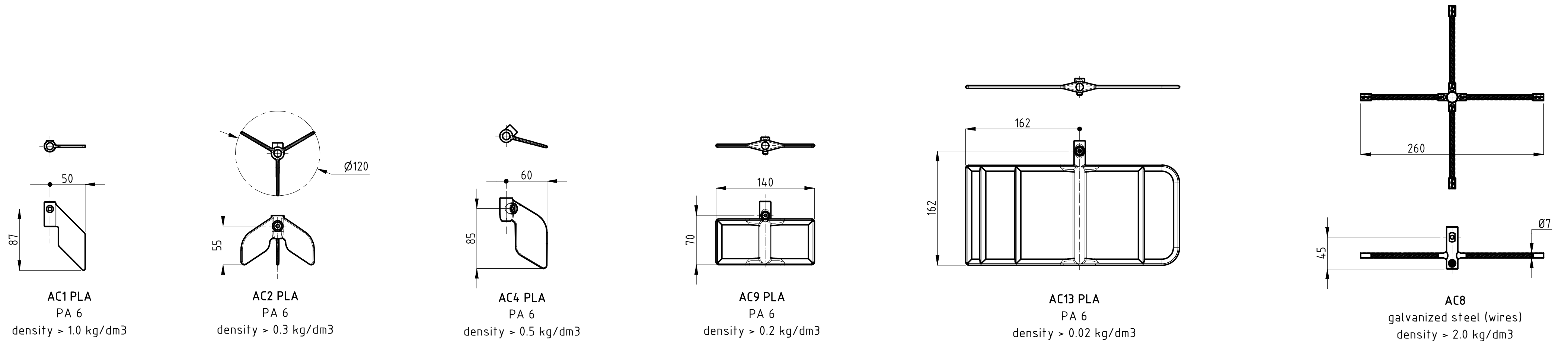
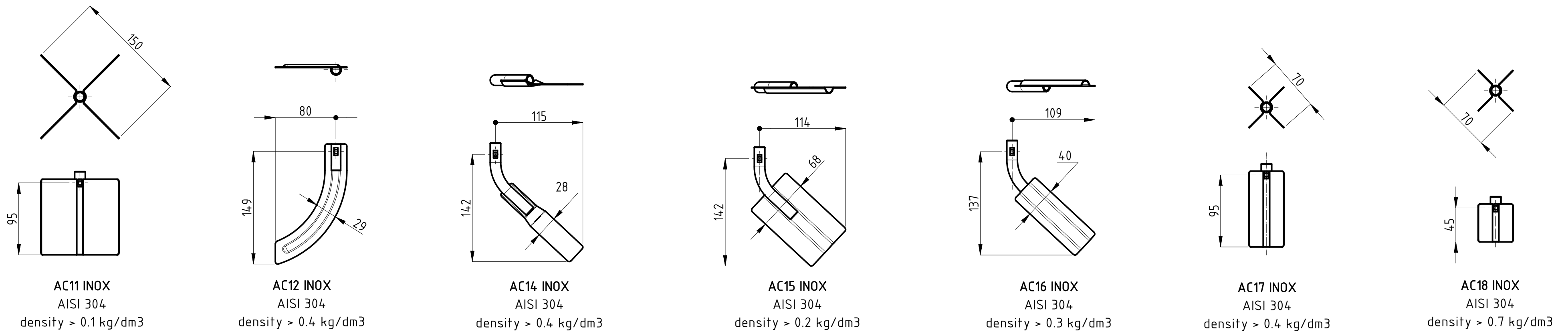
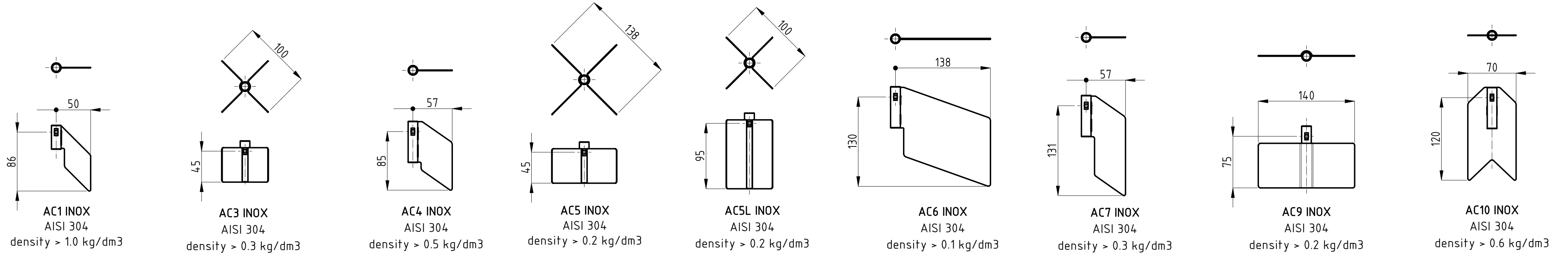

**OPTIONS**

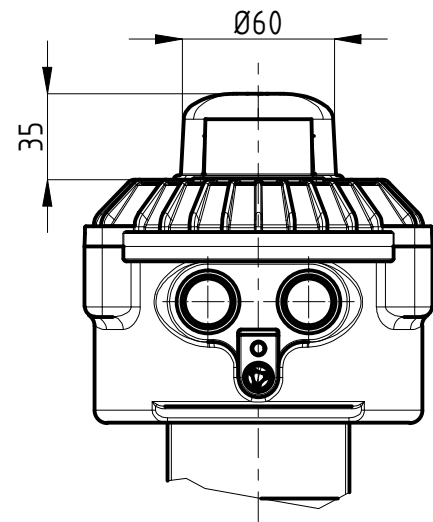

**SIGNAL LAMP (PFG05.../L)**

Adds a LED lamp on top. The lamp could be connected to NC contact (MIN level - empty), or NO contact (MAX level - full).

Must define a single power supply voltage: 24[V]  
48[V]  
115[V]  
230[V]

**NOTE**

Model with lamp can be installed only in ATEX zone 22  
Marking: Ex II 3 D Ex tc IIIB T85°C Dc

**DOUBLE DRY CONTACT**

Adds a second signal contact SPDT (terminals 9 - 10 - 11)

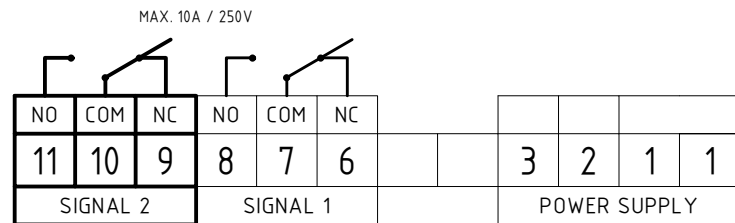

**VOLTAGE CONTROL**

Adds an alarm in case of power supply failure. When power supply is OFF, a relay closes terminals 5 and 7

Must define a single power supply voltage: 24[V]  
48[V]  
115[V]  
230[V]

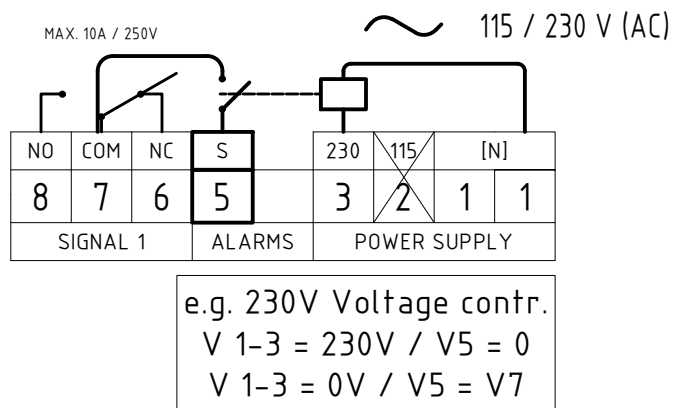

**ROTATION CONTROL**

Adds a signal to indicate shaft rotation. When the shaft rotates, a microswitch generates a pulse signal (8 pulse / rotation) between terminals 1 and 4.

On request, it is possible to have the pulsed signal between terminals 4 and 7.

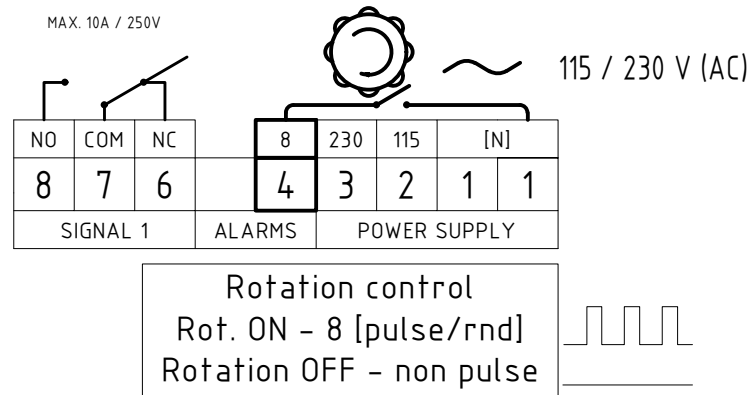

**LOW TEMPERATURE (PFG05.../B)**

Extends the range of use of the indicator down to a minimum temperature of -40 °C

Intelligent automatic operation: when the temperature exceeds + 20 °C it stops heating (heating OFF), it is reactivated when the temperature falls again below + 20 °C (heating ON)

Must define a single power supply voltage: 24[V]  
48[V]  
115[V]  
230[V]

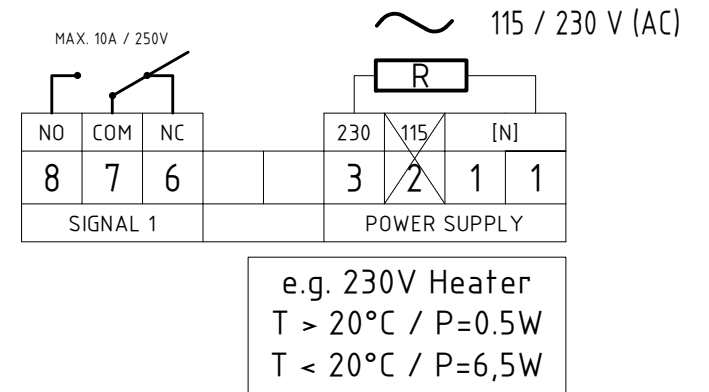

**SPRING TERMINAL BLOCK**

Terminals with spring terminal design. No tool needed for wires connection. 0,13 - 2,5mm<sup>2</sup> (AWG26 - AWG14)

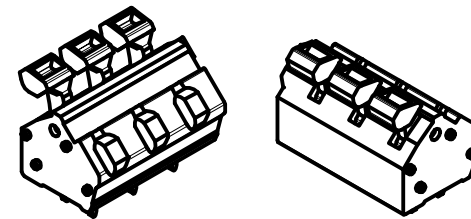

**SCREW TERMINAL BLOCK**

Terminals with screw terminal design (flat head) 0,05 - 2,5mm<sup>2</sup> (AWG30 - AWG12)

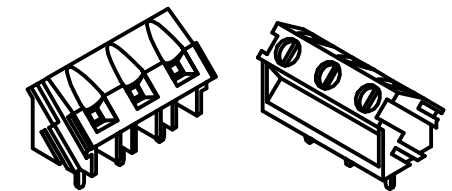

**4rpm GEARMOTOR**

Increase paddle speed (4 rpm) to reduce product detection delay time (response time ~ 1,5s)

**CONDENSATION FILTER**

It allows the exchange of air temperature and pressure with the ambient, preventing the formation of condensation. The option does not alter the IP grade and the Ex marking of the device.